

E 1930 - Safety guidelines

1. Description

The E 1930 transport bar serves the function of easy and safe transport of Meusburger standard moulds. Additionally, it holds the mould halves together at the parting line. The centre of gravity can be shifted and fixed. The large distance between transport bar and mould allows enough space for overhanging parts like fittings and connectors. During operation of the mould the transport bar has to be removed. The E1930 is designed for the transport of plastic injection moulds.

2. Safety instructions

- » Check the transport bar regularly and before each use. Make sure the screws are tight and pay attention to significant signs of corrosion, wear or deformation.
- » The product must only be used by authorized and instructed persons, taking country specific statutory regulations into account.
- » Choose the respective transport bar by using the working load table (see figure 1).
- » A planar bolting surface must be guaranteed. The bores shall be arranged symmetrically to the parting line (see figure 2). Take the strength of the used material into account when choosing the screws and when deciding about the minimum bolt length (l_{min}):
 - 1,5 x M in case of steel
 - 2 x M in case of aluminium
 - 2,5 x M in case of low-strength light alloys
- » Fix the screws tightly with an Allen or torque wrench (see figure 3). Align the eye bolt with the axis of the centre of gravity and then tighten it up to ensure stability.
- » The lifting device shall move freely in the eye bolt of the E 1930. Pinch-, shear- and wrap points as well as impacts must be avoided when connecting and disconnecting the lifting device (sling chain, round sling, wire rope). Damage of the lifting device caused by sharp edges should be avoided as well.
- » The transport bar can be used at temperatures ranging between -20°C and 200°C . Parts of the E 1930 must not come in contact with aggressive chemicals, acids or vapours from these.
- » Loads must not be lifted over people.

max. kg	No.
150	E 1930/ 44/ 80
230	E 1930/ 64/ 97
700	E 1930/ 82/107
1200	E 1930/100/155

Fig. 1 - Working load table

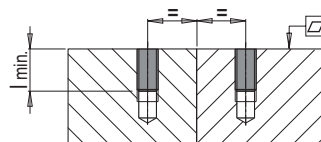

Fig. 2 - Positions of the bores

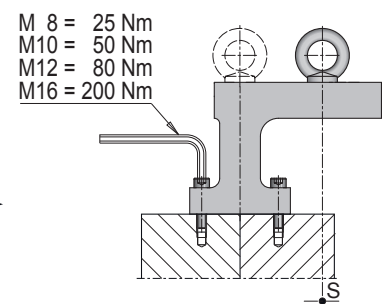
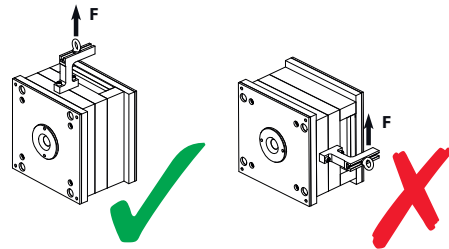

Fig. 3 - Tightening torques for cylinder head screws and grub screws 8.8

- » Weight must only be put on the eye bolt when under tension. The maximum inclination of 6° must not be exceeded.



3. Maintenance and inspection:

Before each use check the transport bar for:

- » deformations of the component parts such as body and screws
- » mechanical damage like cracks or deep notches, particularly in high stress areas.
- » significant corrosion
- » proper functioning of the screws and/or threads / damage to the screws or threads
- » tightness of the screws

After assembly and repair works as well as after a certain period of time (depending on the frequency of use) and at least once a year the transport bar must be examined for further usability by an expert. Especially damage at the eye bolt has to be paid attention to. Damaged parts must only be replaced by genuine parts. Make sure to provide corrosion protection for the transport bar during storage.

4. Spare parts list:

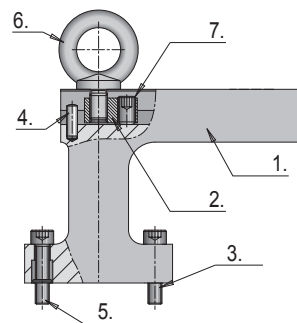

Pos.	Designation	No.	Pcs.
1.	main body	E 19301	1
2.	slot nut	E 19302	1
3.	cap screw	E 1200	2
4.	dowel	E 1300	2
5.	o-ring	E 2130	2
6.	eye bolt	E 1270	1
7.	set screw	E 1230	1